

ATTENTION PLEASE CHECK THE ULTRAFLO WEBSITE AT www.ultraflovalve.com TO ENSURE YOU HAVE THE MOST RECENT COPY OF THIS DOCUMENT

NOTES:

1. ALL DIMENSIONS IN INCHES
2. VALVE WITH FULLCUT DISC CARRIES A PRESSURE RATING OF 150 P.S.I.
3. VALVE O.D. AND FLANGE BOLT CIRCLE MUST SHARE COMMON CENTER LINE. VALVE DESIGN TO BE PLACED BETWEEN ANSI 125 OR 150 LB FLANGES (NOT FOR USE WITH ASA 250 OR 300 LB FLANGES).
4. TEFLON LINED VALVES ARE UNSUITABLE FOR SLIP-ON FLANGES
5. Q DIMENSION: IS THE MINIMUM FLANGE OR PIPE I.D. TOLERABLE FOR PROTECTION OF DISC SEALING EDGE WHILE OPERATING CENTERED BETWEEN FLANGES.

2"-6" HAVE AN ADDITIONAL 5TH HOLE DRILLED IN TOP PLATE THAT WILL ENABLE VALVE TO BE LOCKED IN THE CLOSED POSITION WHEN USING A LOCKING HANDLE

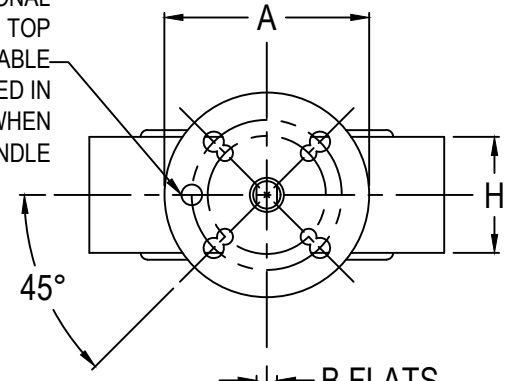

GROOVES ON BODY O.D. ACCOMODATE LIGHTWEIGHT FLANGES. GROOVES ARE NOT NEEDED ON 2.5", 8" OR 12" HOUSINGS

BODY SCREWS 2

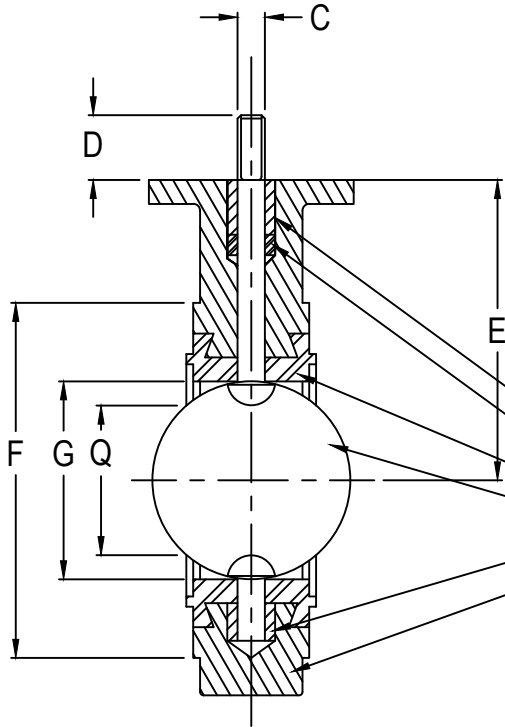

NAME	NUMBER REQUIRED	MATERIAL	PART NUMBER
UPPER BUSHING	1		
PACKING	1		
SEAT	1		
DISC-STEM	1		
LOWER BUSHING	1		
BODY	1		

VALVE DIMENSIONS											TOP PLATE DRILLING					
											ISO DRILLING			STD DRILLING		
SIZE	A	B	C	D	E	F	G	H	Q	WT. LBS	B. CIRCLE	HOLES	HOLE DIA.	B. CIRCLE	HOLES	HOLE DIA.
2	4.000	.375	.563	1.250	4.063	4.125	2.125	1.625	1.531	6.0	2.760	4	.375	3.250	4	.438
3	4.000	.375	.563	1.250	5.000	5.375	3.125	1.750	2.689	9.0	2.760	4	.375	3.250	4	.438
4	4.000	.438	.625	1.250	6.000	6.875	4.125	2.000	3.719	11.0	2.760	4	.375	3.250	4	.438
5	4.000	.438	.625	1.250	6.000	7.750	5.188	2.125	4.813	15.0	2.760	4	.375	3.250	4	.438
6	4.000	.500	.750	1.250	6.625	8.750	6.125	2.125	5.813	17.0	2.760	4	.375	3.250	4	.438
8	6.000	.625	.875	1.250	8.313	11.000	8.125	2.500	7.813	29.0	4.020	4	.438	5.000	4	.562
10	6.000	—	1.125	2.000	9.125	13.375	10.125	2.500	9.906	44.0	4.020	4	.438	5.000	4	.562
12	6.000	—	1.125	2.000	10.625	16.125	12.094	3.000	11.844	85.0	4.020	4	.438	5.000	4	.562

10" AND 12" C SIZE STEM CONNECTION DIAMETER WITH 1/4" X 1/4" KEYWAY.

ZONE	REV	DATE	BY	APP'D	ECN	DESCRIPTION
A4	5	07/22/19	TAL	JPL		REMOVED 2.5 INCH VALVE
A1	4	05/06/10	DSS	CJH	374	UPDATED TITLEBLOCK
E4	3	07/06/09	CJH	CJH		ADDED TEFLON NOTE
E2	2	06/20/05	TJM	TJM		ADDED DRAWING NOTES
E4	1	02/22/05	TJM	TJM		ADDED NOTE

Ultraflo Corporation
A Subsidiary of Bray International, Inc.

#8 Trautman Ind. Dr.
Ste. Genevieve, Mo.
63670 800-950-1762

DRAWN BY	TJM	DATE	05/25/98
CHECKED	TJM	DATE	05/25/98

PART: 390 VALVE WAFER BODY, ONE-PIECE DISCSTEM, EPDM, NITRILE, VITON, BUNA OR TEFLON SEAT

ECN:
DWG: 390/393-2